

# THE MEASUREMENT OF FLAME SPEEDS<sup>1</sup>

ERNEST F. FIOCK AND CHARLES F. MARVIN, JR.

*National Bureau of Standards, U. S. Department of Commerce, Washington, D. C.*

*Received July 17, 1937*

## INTRODUCTION

When an explosive mixture of gases is ignited by a spark from within, flame spreads in all directions from the point of ignition. The observed spatial velocity of the flame front in any direction is always the resultant of two component velocities,—(1) the speed of propagation relative to the unburned gases, and (2) the speed at which the flame front is transported bodily in a direction normal to its surface by mass movement of the gases comprising it. The first component, or the speed at which the reaction zone advances into and transforms the unburned charge, is a characteristic property of the explosive mixture. This property, which for brevity will be termed the “transformation velocity,” has considerable practical and theoretical importance. The second component or “gas velocity” and the resultant speed in space are of minor fundamental interest, since they vary with the size and shape of the explosion vessel and are influenced by general movements initially present in the gaseous charge or established during combustion.

Unfortunately, very few of the many available records of the spatial movement of flame in bombs, tubes, and engines can be analyzed to yield accurate values of transformation velocity. Reliable experimental data showing the separate effects of the various operating factors upon this fundamental flame speed are extremely scarce. Moreover, the micro-mechanism of flame propagation is still so obscure that there is no adequate basis for calculating transformation velocities from theoretical considerations.

There is need for a clear general picture on a molecular scale of the structure of flame and its mode of propagation which will permit visualization of the effects upon flame speeds of such basic factors as the pressure, temperature, composition and turbulence of the explosive mixture. Ac-

<sup>1</sup> Publication approved by the Director of the National Bureau of Standards of the U. S. Department of Commerce.

curate experimental values of transformation velocity would be of great assistance in the evolution of a satisfactory theory of flame propagation and are essential to the verification of any such theory.

In the engine, the rate of rise in pressure is largely determined by the transformation velocity of the explosive mixture used. Complete information regarding the effects of composition, temperature, pressure, and turbulence upon this velocity would be of immediate practical value in predicting and controlling rates of pressure rise. Such data, if extended to sufficiently high temperatures and pressures, should also indicate the conditions for incipient fuel knock. Under these conditions high transformation velocities are to be expected, and autoignition of the unburned charge is probably imminent.

For the reasons which have been enumerated, a primary requisite of a satisfactory method for measuring flame speeds is that it must yield reliable values of transformation velocity. Capacity to function properly over a wide range of operating conditions is a decided advantage. The possibility of obtaining simultaneous information on expansion ratio, heat capacity, equilibrium state, or other factors which influence the amount and rate of the rise in pressure should not be overlooked.

Transformation velocities have been measured for stationary flames and flames moving in tubes and bombs of various shapes. The problems of the stationary flame are discussed by another author (6). It is believed that those methods involving spherical flames are susceptible of the most rigorous analysis.

In the present report, both constant-pressure and constant-volume methods involving spherical flames in the absence of detonation are discussed. Applications of these methods are presented and typical results are given to illustrate some of their salient features. The material of this report has been accumulated during the course of investigations sponsored by the National Advisory Committee for Aeronautics.

#### CONSTANT-PRESSURE EXPLOSIONS

One of the simplest methods yet devised for determining transformation velocity is the soap-bubble or constant-pressure method developed by F. W. Stevens. This method has been described (7) and early results obtained by its use have been fully reported before the American Chemical Society (7, 8, 9) and elsewhere (11, 12). A further investigation of the method by Fiock and Roeder (2) led to a number of refinements in the apparatus and procedure which improved considerably the accuracy of the results obtained and indicated more fully the possibilities and limitations of the method.

*Experimental method*

In the improved procedure, a soap bubble, shown in figure 1, is blown by introducing a carefully prepared explosive mixture through the glass tube seen at the top of the photograph. The ring of gold wire just below the mouth of the tube helps to support the bubble, which is blown until its horizontal diameter becomes 9 cm., as shown by its projected shadow on an enlarged scale. The electrodes, projecting upward from the bottom, form a spark gap at the center of the full-sized bubble, which may be blown without difficulty with the gap in position.

High-speed motion pictures, reproduced in figure 2, show that when the spark occurs, a sphere of flame forms at the spark gap and grows steadily in size until all of the explosive mixture is inflamed. During its growth, the

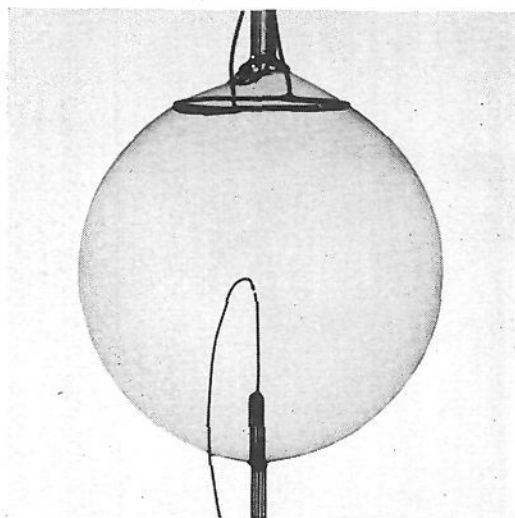

FIG. 1. Soap bubble containing explosive mixture, ready to be fired

flame maintains a spherical shape except for slight local distortions at the supporting ring and the electrodes. The soap film at first distends, then bursts when the flame reaches the gold ring, and finally collapses toward the electrodes without offering appreciable resistance to the progress of the flame. The explosion thus runs its course at constant pressure. There is no measurable convective rise of the sphere of flame during the period of spread except for very slow-burning mixtures. However, the hot gases subsequently rise out of the picture before they cease to glow.

For analytical purposes, the explosion in the bubble is photographed through a narrow slit which leaves only the horizontal diameter visible. The film is carried on a drum rotating at a known constant speed on an axis parallel to the slit. As the diameter of the sphere of flame increases, its lengthening image moves along the film and produces a V-shaped trace

which is a time-displacement record of the travel of the flame front. A typical record is shown in figure 3.

For most mixtures the sides of the V are practically straight, showing that the flame front travels at constant speed. This speed in space ( $S_s$ )

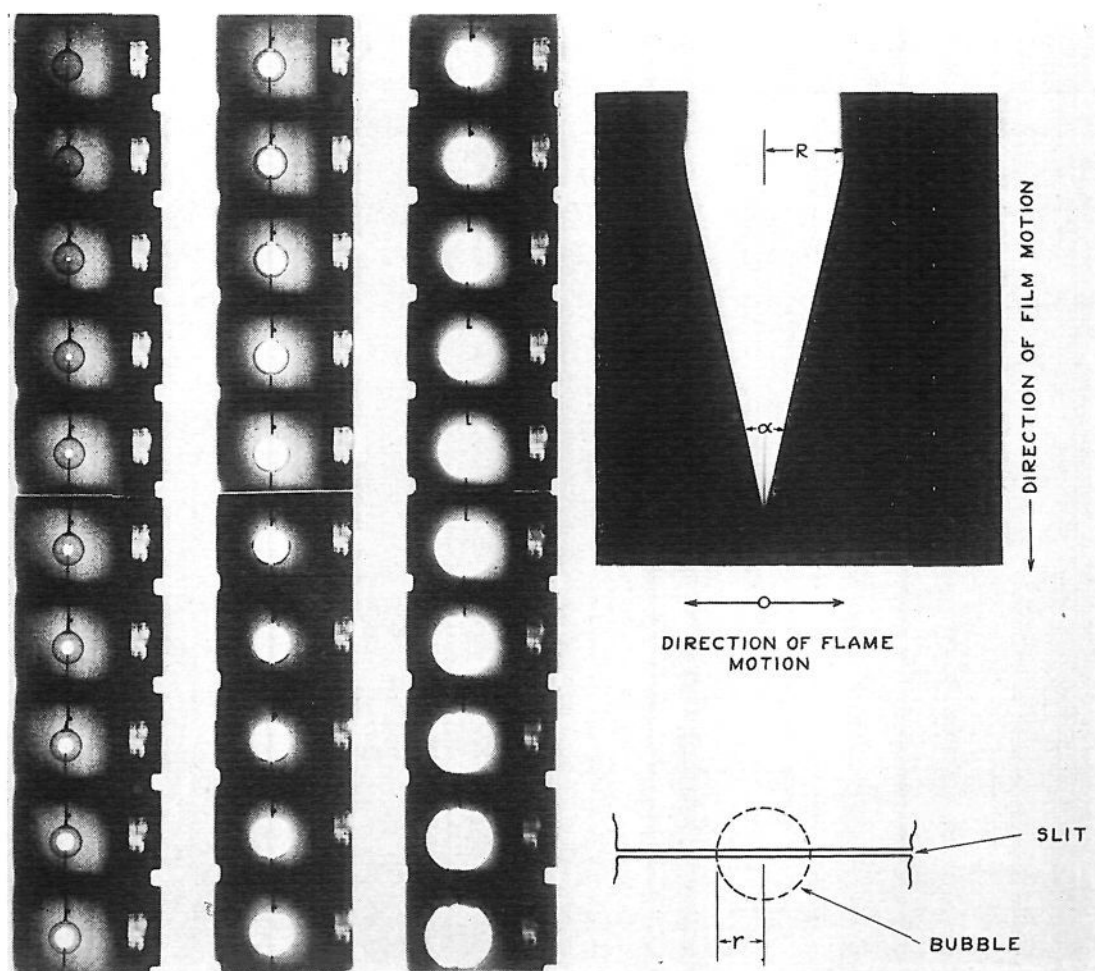

FIG. 2

FIG. 3

FIG. 2. High-speed motion-picture record of an explosion in a soap bubble (1610 frames per second)

FIG. 3. Method of recording an explosion in a bubble on a rotating film

can be calculated from the angle ( $\alpha$ ) of the V, the known speed ( $F$ ) of the film, and the magnification factor ( $m$ ) for the camera, through the relation

$$S_s = mF \tan \frac{\alpha}{2} \quad (1)$$

Measurements on the film also show that the final diameter of the sphere of hot gases is much greater than the diameter of the original bubble. The ratio of the volume of the burned products to that of the unburned charge is the expansion ratio  $E$  for the mixture when burned at constant

pressure. If  $r$  is the radius of the bubble before firing and  $R$  is the maximum radius of the sphere of hot gases as measured on the film, then

$$E = \frac{(mR)^3}{r^3} \quad (2)$$

The flame not only advances into and transforms the explosive mixture but simultaneously it is carried bodily outward by the expansion of the gases within it. Stevens (7) showed that the transformation velocity  $S_t$  may be computed from the speed in space and expansion ratio through the relation

$$S_t = \frac{S_s}{E} \quad (3)$$

Values of  $E$  may also be used to calculate the temperature of the hot gases at the instant the flame has completed its travel, if sufficient equilibrium data are available from the other sources (2).

It was known, prior to the application of the bubble method, that water vapor had a large effect upon the speed of flame in space in mixtures of carbon monoxide and oxygen. For this reason it was necessary to control the quantity of water vapor in the explosive mixtures during the formation and life of the bubbles. It was found by Fiock and Roeder that the transfer of water vapor to or from the atmosphere surrounding the bubble was quite rapid, and that the partial pressure of water vapor had to be made identical in the mixture, the soap solution, and the surrounding air. This was accomplished by blowing the bubbles at the center of a large chamber at a controlled temperature and humidity corresponding to the vapor pressure of the soap solution.

#### *Effect of fuel-oxygen ratio*

Since the experiments of Stevens were made without adequate control of the moisture content of the air in which the bubbles were blown, some of his measurements were repeated with more accurate control of conditions. Figure 4 shows the effect of mixture ratio upon flame speeds and expansion ratio for various mixtures of carbon monoxide and oxygen, each initially at 25°C. and containing 2.69 per cent of water vapor by volume. The plotted values of  $E$  and  $S_s$  were calculated directly from measurements on the photographic records. Values of  $S_t$  were obtained from the smooth curves for  $S_s$  and  $E$ .

As a result of a large number of experiments on the system carbon monoxide-oxygen it has been concluded that both  $S_s$  and  $S_t$  have maximum values slightly on the rich (in carbon monoxide) side of chemical equiva-

lence. Values of  $E$ , however, change so little on either side of equivalence that it is impossible to locate the maximum from the data available.

All experience indicates that the mechanics of the explosion in a soap film and the method of analyzing the results were correctly postulated by Stevens. However, he concluded that the speed of flame relative to the unburned gas was directly proportional to the mass action product of the concentrations of the active constituents in the original mixture. Applied specifically to the explosive oxidation of carbon monoxide, this statement

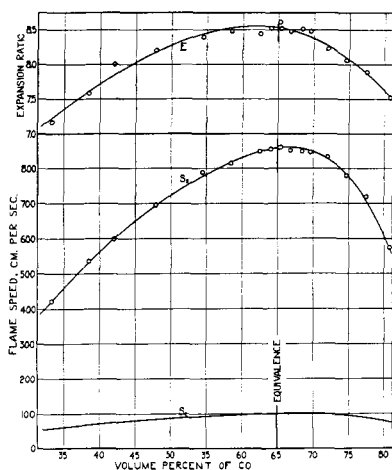

FIG. 4

FIG. 4. Effect of fuel-oxygen ratio on combustion characteristics of mixtures of carbon monoxide and oxygen. ( $H_2O = 2.69$  per cent.)

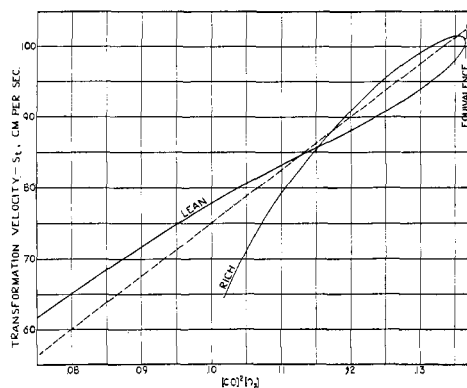

FIG. 5

FIG. 5. Relation between transformation velocity ( $S_t$ ) and the mass action product for mixtures of carbon monoxide and oxygen. ( $H_2O = 2.69$  per cent.)

means that the relation between  $S_t$  and the initial concentrations of carbon monoxide and oxygen is expressed by the equation,

$$S_t = k[CO]^2[O_2] \quad (4)$$

in which  $k$  is a constant for each value of water vapor content and the bracketed symbols indicate concentrations of the reactants. The more precise data fail to confirm this relation. Instead of being directly proportional to the mass action product, the transformation velocity varies with it in the complex manner shown in figure 5. The equation, regardless of the value of  $k$ , gives a maximum value of  $S_t$  at exact equivalence, while the observed maximum values of both  $S_s$  and  $S_t$  are definitely on the rich side of equivalence. It therefore seems necessary to abandon Stevens' concept

of the proportionality of  $S_t$  to the initial composition and to resume the search for a relation which is in better accord with the observed facts.

Mixture ratio affects not only flame speed but also the intensity of the light emitted by the explosion. The density of the photographic records decreases on either side of equivalence, as shown in figure 6. On the lean

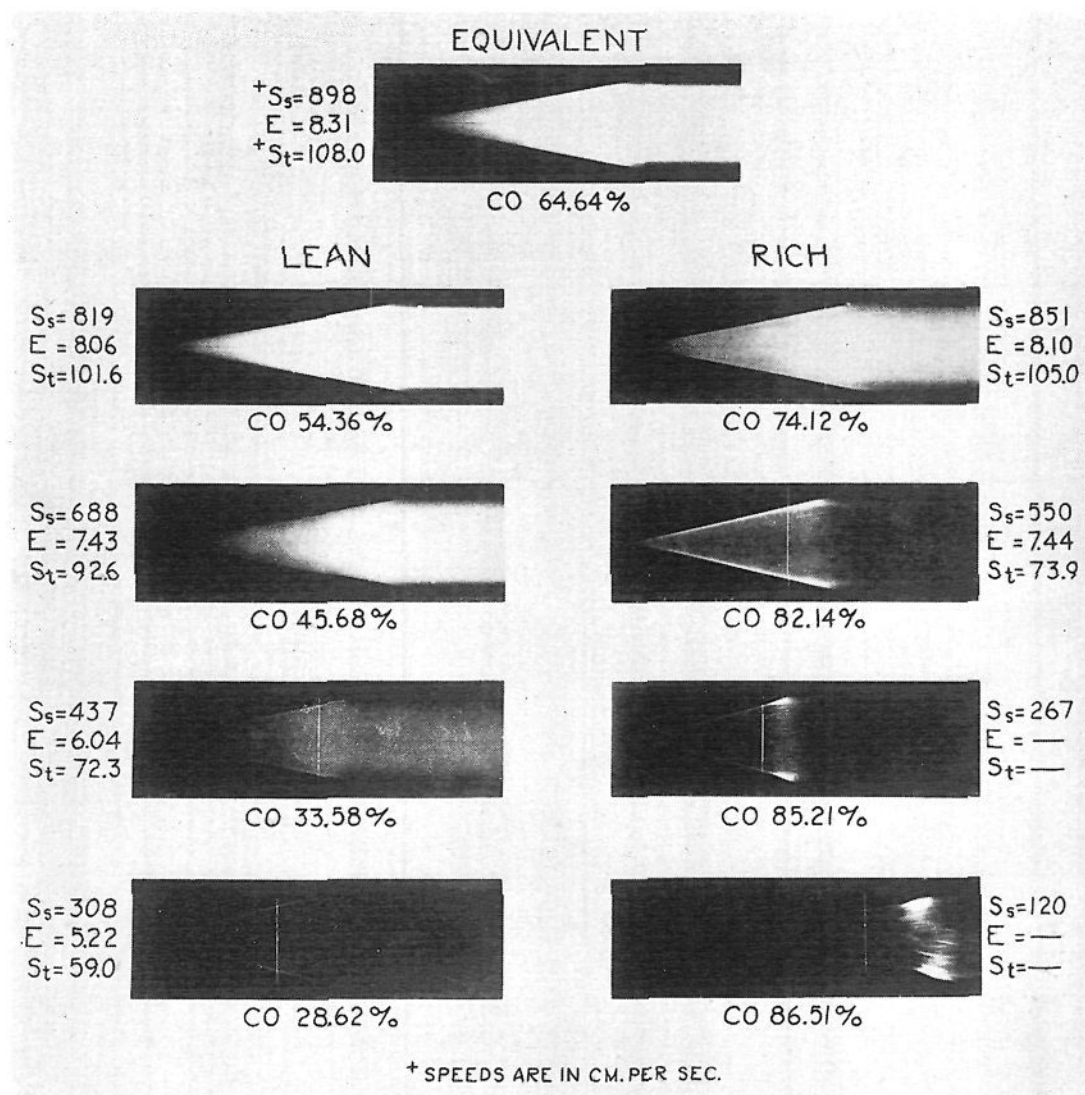

FIG. 6. Photographic records of explosions in bubbles for various mixtures of carbon monoxide and oxygen. ( $H_2O = 3.31$  per cent.)

side, in the range near equivalence, the afterglow seems to emit more actinic light than the flame front. On the rich side the afterglow soon becomes very faint, then disappears entirely. At both extremes the flame front appears on the records as a line of much greater density than the image of the hot gases which are surrounded by the reaction zone. For very rich mixtures a somewhat irregular flame appears after the excess of

fuel has mixed with the oxygen of the surrounding air. In such cases the measurement of final volume (and hence also of  $E$  and  $S_t$ ) is impossible.

*Effect of inert gases*

Figure 7 shows the effect on flame speed and expansion ratio of replacing various portions of the active gases carbon monoxide and oxygen with helium or argon. The ratio of carbon monoxide to oxygen had the constant value of 1.811 and the water vapor content was 2.69 per cent throughout. Since it is necessary in the bubble method to hold the moisture content of the mixture constant, the ratio of water vapor to active gas

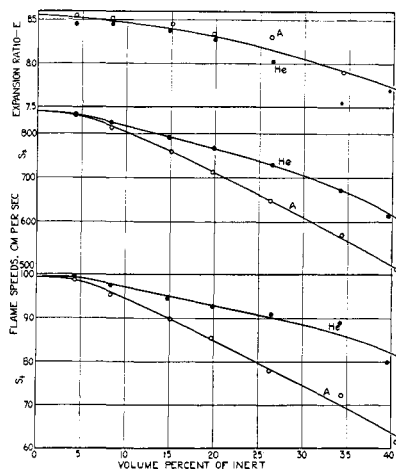

FIG. 7

FIG. 7. Effects of argon and helium on combustion characteristics of mixtures of carbon monoxide and oxygen. ( $\text{CO}/\text{O}_2 = 1.811$ ;  $\text{H}_2\text{O} = 2.69$  per cent.)

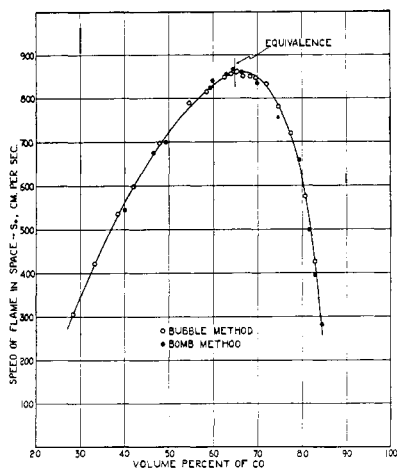

FIG. 8

FIG. 8. Speed of flame in space for various mixtures of carbon monoxide and oxygen as determined by the bomb and bubble methods. ( $\text{H}_2\text{O} = 2.69$  per cent.)

increased as more inert gas was added. From other experiments it is known that such an increase in the proportion of water vapor causes a decrease in  $E$  and an increase in  $S_s$  and  $S_t$ . Thus the decrease in  $E$  would have been less and the decrease in  $S_s$  and  $S_t$  would have been more than that shown by the curves if the ratio of the concentration of carbon monoxide and water vapor could have been kept constant. Similar results have been obtained at various other ratios of carbon monoxide to oxygen (3).

The decrease in  $E$  with increasing concentration of inert gas is due to the fact that less active mixture and therefore less heat is available to raise



the temperature of the same volume of gas. However, the specific heats of both argon and helium are much lower than that of the carbon dioxide which they replace in the final combustion products. Also the lower final temperature permits a greater conversion of carbon monoxide and oxygen to carbon dioxide and reduces the heat lost by radiation. Because of these effects  $E$  decreases more slowly than does the concentration of the active mixture. Interpreted in terms of engine performance, the addition of inert gas would tend to decrease the maximum power available but should increase the efficiency of fuel utilization.

Regardless of the mechanism by which flame propagates, the replacement of active mixture by inert gas may be thought of as the introduction of a resistance, in the form of intermediate collisions, to the transfer of energy in some form from the flame to the unburned gas. The magnitude of the resistance depends upon characteristics of the inert gas which have not yet been definitely identified. Such a resistance is doubtless responsible for the observed decrease in transformation velocity with increasing concentration of inert gas.

Direct comparisons of the effects of like volumes of argon and helium are possible from data at hand. These data show that both argon and helium have practically the same effect upon expansion ratio, but very different effects upon flame speed. For all values of the ratio  $\text{CO}/\text{O}_2$  from 0.5 to 3.8, a given volume of helium produces a smaller decrease in flame speed than a like volume of argon. The differences in both  $S_s$  and  $S_t$  produced by like volumes of argon and helium are independent of the fuel-oxygen ratio and approximately proportional to the concentration of inert gas.

#### CONSTANT-VOLUME EXPLOSIONS

##### *Measurements of the speed of flame in space*

When an explosion in a closed bomb with transparent walls is photographed, the initial portion of the flame record is identical with that obtained by the bubble method, although the movement of the flame is subsequently modified by the restraining effect of the bomb walls. Figure 8 compares flame speeds in space as determined by the bubble method with corresponding speeds for the same mixtures fired in a bomb made from a glass cylinder 6 in. in diameter and 6 in. long, with metal disks and rubber gaskets sealing the ends. The two sets of data agree within the experimental error.

Substitution of a constant-volume bomb for the soap film makes it possible to vary the water vapor content and the pressure of the mixture independently. Figure 9 shows the effect upon  $S_s$  of changing the moisture content in equivalent mixtures of carbon monoxide and oxygen at a number

of initial pressures. The explosions at atmospheric pressure were made in the cylindrical bomb just mentioned. The data at lower pressures were obtained in a 5-liter spherical glass flask. Both bombs were provided with central ignition.

From mixtures too dry to ignite or photograph properly to those which were saturated with water vapor at room temperature and the pressure of the experiment, an increase in moisture content always produced an increase in flame speed. Successive equal increments of moisture have diminishing effects upon flame speed, and there is doubtless some concentration beyond which further addition of water vapor will produce a decrease in flame speed. If it had been practicable to maintain the explo-

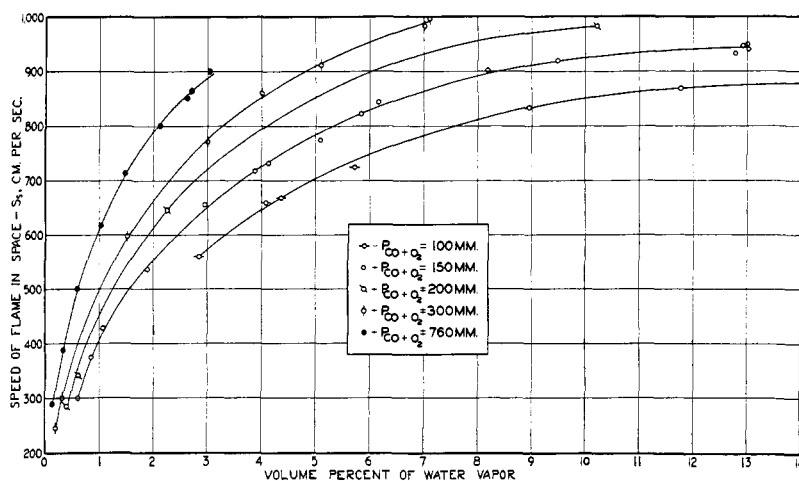

FIG. 9. Effects of water-vapor content and initial pressure on speeds of flame in space for equivalent mixtures of carbon monoxide and oxygen.

sion vessel at an elevated temperature, it is believed that this concentration might have been reached at each of the dry-gas pressures studied. Figure 9 shows also that equal increments of moisture cause more increase in flame speed at the higher pressures. It is quite evident that water-vapor content must be carefully controlled and specified if determinations of flame speed in mixtures of carbon monoxide and oxygen are to be significant.

In normal photographic records of comparatively fast-burning mixtures of carbon monoxide and oxygen, fired in either a soap bubble or bomb, the flame appears to attain its maximum velocity in space at the instant of the spark. If, however, the film is moved at an abnormally high speed, the records show that there is a very short interval, just after ignition, in

which the flame has a positive acceleration, as evidenced by the curvature of the traces. The diagram on the right in figure 10 shows this early period of flame travel on a magnified scale.

The straight portion of the flame trace  $SF$  may be extended until it intersects at point  $A$  the axis  $SD$ , drawn through the spark  $S$ . The time interval  $SA$  is the increase in the duration of the explosion caused by the initial slow movement of the flame and will be termed briefly the "delay."

The curve of figure 10 shows that the delay increases greatly as the concentration of water vapor is reduced in equivalent mixtures of carbon

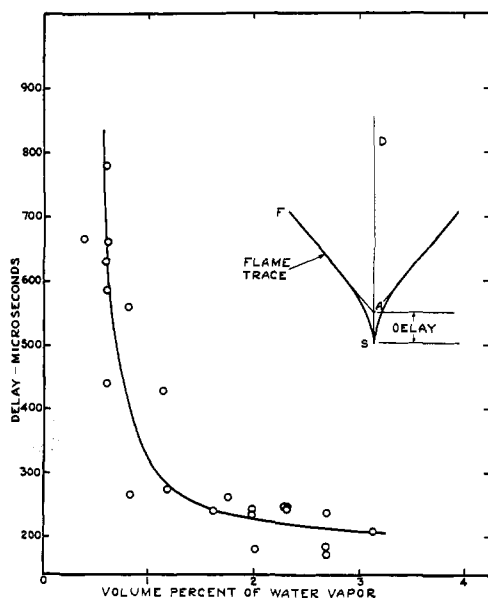

FIG. 10. Effect of moisture content on the delay period for equivalent mixtures of carbon monoxide and oxygen at atmospheric pressure.

monoxide and oxygen, initially at atmospheric pressure. Reducing the pressure at constant water-vapor concentration also increases the delay markedly, but quantitative measurements are difficult because of the decrease in the actinic light emitted by the explosions.

The real significance of the delay period is not known. It is possible that the low initial speeds of flame in space result chiefly from subnormal values of  $E$ , which in turn may be associated with the establishment of an equilibrium depth and structure of the reaction zone. If the normal reaction zone has a considerable depth, the flame front must travel at least this same distance from the point of ignition before the equilibrium

structure is established. Previous to the attainment of such an equilibrium state, both  $S_t$  and  $E$  may be abnormally low and increasing toward their normal values.

*Proposed experimental method*

While flame records obtained in constant-volume bombs yield, directly, values of the speed of flame in space, means for measuring the rise in pressure must be provided if values of transformation velocity are to be obtained. Lewis and von Elbe (4) have derived values of this property for

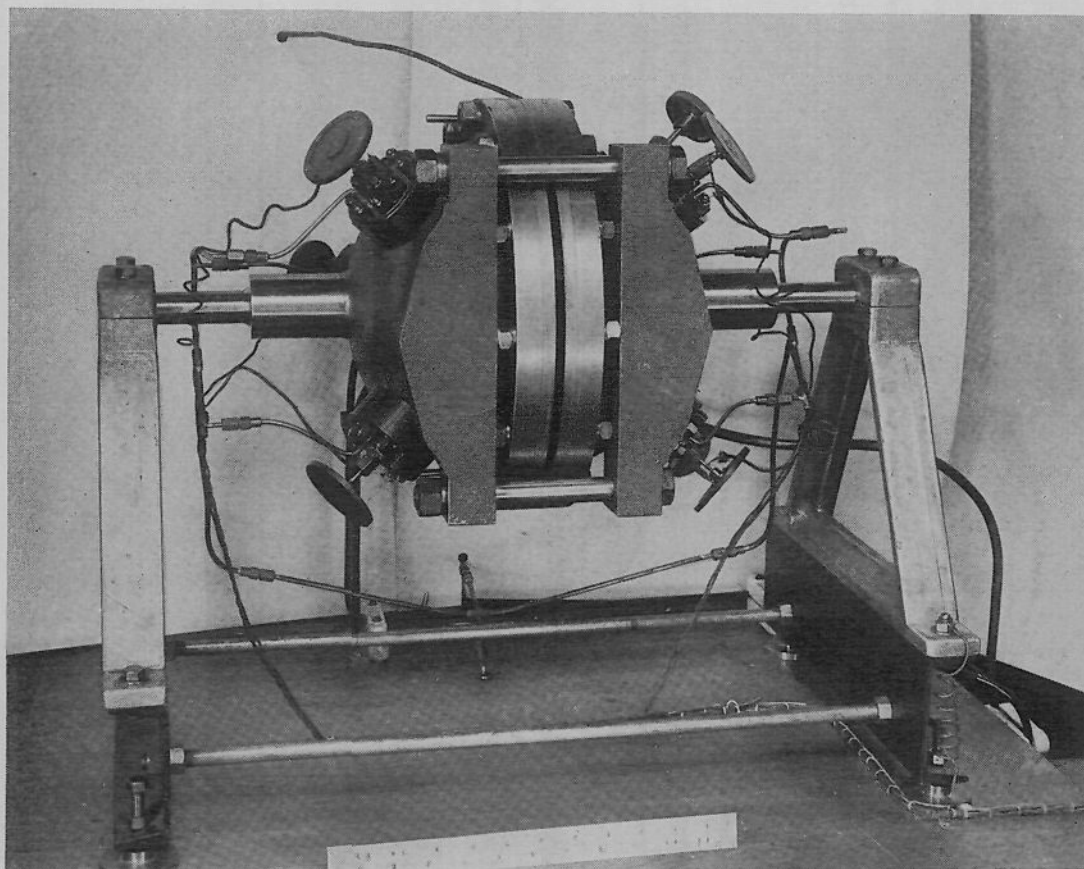

FIG. 11. Spherical steel bomb equipped to yield simultaneous records of flame travel and pressure development.

ozone explosions from time-pressure records alone. However, if experimental records of both flame travel and pressure development are obtained, the observed quantities can be reduced to the desired properties in a simpler and more positive manner. A spherical bomb and auxiliary equipment designed to yield these two records simultaneously have been constructed at the National Bureau of Standards.

This bomb, shown in figure 11, is composed of two flanged hemispheres of stainless steel, clamped together upon a short cylindrical ring of glass. It is mounted with a narrow window in the vertical position so that the

presence or absence of convective rise during burning may be detected. The spread of flame from the central point of ignition is photographed on a rotating film as in the bubble experiments. Six diaphragm indicators are provided to measure the rise in pressure which is recorded on the film with the flame trace.

Figure 12 is a diagrammatic representation of the spherical bomb with its window, and includes a comparison of typical flame traces for bomb and soap bubble.

When a spark occurs at the center of the bomb, a sphere of flame starts to spread exactly as in the constant-pressure explosion. However, the walls of the bomb soon resist the outward flow of gas set up by the expansion, and the unburned charge is compressed instead of merely being moved away by the advancing flame front. Thus the expanding gases cannot

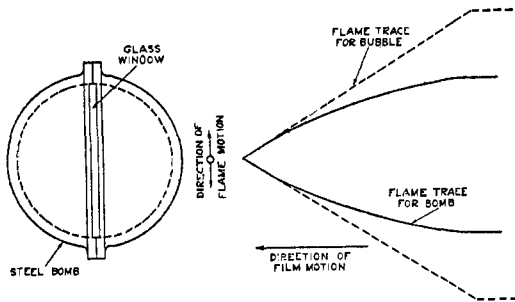

FIG. 12

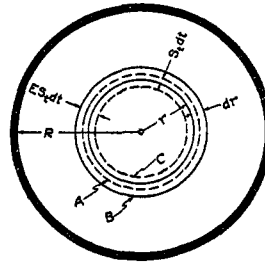

FIG. 13

FIG. 12. Comparison of flame records obtained in the bomb and bubble methods  
 FIG. 13. Diagrammatic section indicating the significance of mathematical terms

push the flame front outward as fast or as far as in the bubble explosion. As a result of the steadily decreasing outward gas velocity, the flame front travels more slowly as it approaches the walls, even though it may be propagating into the compressed and heated unburned charge at an ever-increasing speed.

The slopes of the flame traces shown in figure 12 constitute a direct measure of the speeds of flame in space. The slope of the trace of the flame in the bomb gradually decreases from the constant value of that in the bubble until it reaches a value at the wall which is a measure of the transformation velocity of the last portion of the charge to burn. This condition must always prevail since the last of the gas to burn cannot move beyond the walls, and is, therefore, essentially at rest when traversed by the flame.

Consider, as illustrated in figure 13, that the flame front, in a spherical

bomb of radius  $R$ , has a radius  $r$  at time  $t$  after ignition. In the next increment of time  $dt$ , the reaction zone will transform a shell of gas of thickness  $S_t dt$ , which, upon expansion, will advance the flame front a total distance  $dr = S_s dt$ . Thus the remaining unburned gas is compressed from an inner boundary represented by the dotted line  $A$  to one represented by the solid line  $B$ , with an accompanying rise  $dp$  in pressure.

Applying the adiabatic law in differential form to this compression of the unburned charge gives

$$\frac{dp}{p} = \frac{-k_u dV_u}{V_u} = \frac{-3k_u r^2 (S_t dt - dr)}{R^3 - r^3} \quad (5)$$

in which  $k$  is the adiabatic exponent,  $V$  is total volume, and the subscript  $u$  refers to the unburned gas.

Equation 5 reduces to the form

$$S_t = S_s - \frac{(R^3 - r^3)}{3pk_u r^2} \frac{dp}{dt} \quad (6)$$

If  $E$  is the expansion ratio at time  $t$  and pressure  $p$ , the shell of unburned gas of thickness  $S_t dt$  will expand, upon burning, to a volume of  $4\pi r^2 E S_t dt$ , compressing the previously burned gas to an outer boundary represented by dotted line  $C$  in figure 13. The observed increase in total volume of the burned gas is only  $4\pi r^2 dr$ , and the actual change in volume of the previously burned gas is therefore the difference  $4\pi r^2 (dr - E S_t dt)$ .

Applying the adiabatic law now to the compression of the previously burned gas, using the subscript  $b$  to designate properties of gas in this state,

$$\frac{dp}{p} = \frac{-k_b dV_b}{V_b} = \frac{3k_b (E S_t dt - dr)}{r} \quad (7)$$

which reduces to

$$E = \frac{1}{S_t} \left[ \frac{r}{3pk_b} \frac{dp}{dt} + S_s \right] \quad (8)$$

The recompression of the burned gas by the subsequent expansion of surrounding layers is complicated by the shifts in equilibrium that accompany the compression and by the existence of both temperature and concentration gradients. When the burning has progressed to the stage where these effects are no longer negligible, it is difficult, if not impossible, to fix upon a value of  $k_b$  which will accurately represent the compression of the burned gases. However, the value of  $k_b$  has only a small effect upon the calculated value of  $E$  for the early stages of the explosion. Thus reliable values of  $E$  at the initial condition may be had, even though the selected value of  $k_b$  is somewhat uncertain. When the dissociation is

negligible or calculable, the temperature, density, and concentration gradients which exist in the burned gas may be evaluated by a method such as that developed by Mache (5) and applied by Lewis and von Elbe (4) in obtaining numerical results for ozone-oxygen explosions.

The quantity  $\frac{dp}{dt}$  may be eliminated from equations 6 and 8, yielding the equation

$$ES_t = S_s + \frac{k_u r^3}{k_b} \frac{(S_t - S_s)}{(R^3 - r^3)} \quad (9)$$

If the explosion takes place at constant pressure,  $R$  is infinite and equation 9 reduces to  $ES_t = S_s$ , which is the relation (equation 3) used in calculating  $S_t$  from the bubble experiments.

The conditions existing in the unburned gas at any instant may be calculated from the observed value of pressure, through the adiabatic law. From the experimentally determined variations of pressure and flame radius with time, values of the slopes  $\frac{dr}{dt} = S_s$  and  $\frac{dp}{dt}$  may be found for any value of  $p$ ,  $r$ , or  $t$  during an explosion at constant volume. Accurate values of  $k_u$  are available in the literature.

During an explosion at constant volume there will be a loss of heat from the layer of unburned gas nearest the walls of the bomb, tending to cause an ever-increasing departure from adiabatic compression as the temperature, density, and fraction of the remaining unburned gas in contact with the walls increase. On the other hand, the unburned gas may absorb some of the radiant energy from the flame, either directly or after it is reflected from the polished walls of the bomb. In the final stages of the explosion, preflame reactions may supply heat to the unburned charge. Since the total time of burning is very short, these effects are probably very small individually, and since they are not all in the same direction, their net effect will also be small. Certainly they may be ignored during the earlier stages of the explosion when temperature rises very little.

It is only during the very late stages of the burning that the temperature and pressure of the unburned gas change greatly. Here the departures from true adiabatic compression undoubtedly become appreciable, and the temperature of the unburned gas, as calculated from the observed pressure, is far less certain. Despite this fact, it is evident from equation 6 that the calculated values of  $S_t$  do not decrease in accuracy, because the term

$$\frac{(R^3 - r^3)}{3pk_u r^2} \frac{dp}{dt}$$

assumes a rapidly diminishing importance as  $r$  approaches  $R$ .

Some very short but finite time will elapse before the rise in pressure, that starts at ignition, reaches pressure indicators at the walls of the bomb. During this brief interval there will be no recorded rise in pressure, the experimental values of  $\frac{dp}{dt}$  will be zero, and the value of  $S_t$  calculated by equation 6 will be identical with  $S_s$ , which is, of course, absurd. However, when the flame speed is well below the velocity of sound, the pressure gradients in the bomb are extremely small and soon become a negligible portion of the pressure rise, whereupon equation 6 becomes valid. Since it appears probable that errors due to non-uniformity of pressure will become negligible before the rise in pressure and temperature of the unburned charge is sufficient to cause significant change in  $S_t$  and  $E$ , there

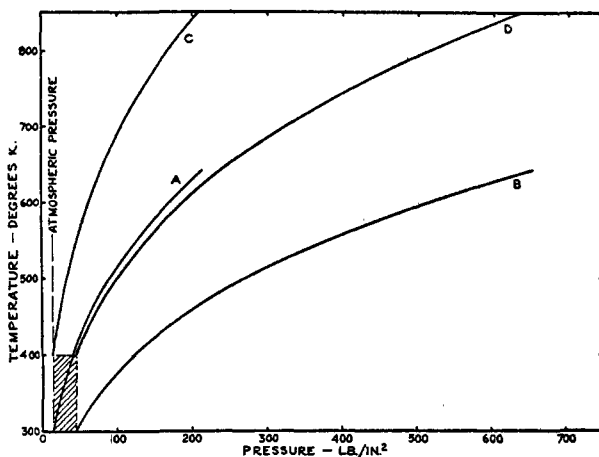

FIG. 14. Simultaneous rise in temperature and pressure resulting from the adiabatic compression of an equivalent mixture of carbon monoxide and oxygen from various initial states.

should be no necessity for attempting to evaluate the very early portion of the pressure curve.

Although the separate effects of charge temperature and pressure cannot be isolated from data on a single explosion, this may be done over a comparatively wide range by varying the initial conditions over a much smaller range.

Curve A of figure 14 shows the simultaneous rise in temperature and pressure of the unburned gas due to compression by the flame of an equivalent mixture of carbon monoxide and oxygen, originally at 300°K. and 1 atm. If the initial temperature is maintained at 300°K. and the pressure is varied between 1 and 3 atm., the range between curves A and B can be studied without special temperature control. If the initial temperature



is  $400^{\circ}\text{K}$ ., a pressure variation of from 1 to 3 atm. permits study of the range between curves C and D. Thus by varying the initial temperature and pressure in the comparatively small range indicated by the shaded rectangle, the entire region between B and C may be investigated. Since most points in this region may be reached from two or more different initial states, opportunity for correlating results at different stages of the explosion is provided.

#### *Pressure measurement*

The utility of time-pressure records of explosions at constant volume has already been cited. Since the accuracy of the derived values of trans-

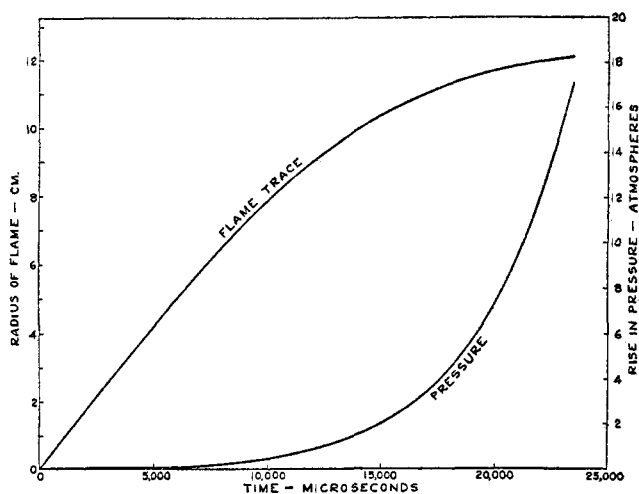

FIG. 15. Calculated time-displacement and time-pressure curves for the explosion of an equivalent mixture of carbon monoxide and oxygen in a spherical bomb of radius 12.2 cm. ( $\text{H}_2\text{O} = 2.69$  per cent.)

formation velocity depends, among other things, upon that of the pressure measurements, these will be discussed briefly by referring to the method which is being used at the National Bureau of Standards.

Figure 15 shows calculated time-displacement and time-pressure records for an explosion in a spherical bomb of an equivalent mixture of carbon monoxide and oxygen, initially at  $300^{\circ}\text{K}$ . and 1 atm. It will be noted that the pressure rises only about 0.2 atm. while the flame traverses half the distance to the wall, and that it rises by about 14 atm. during the last tenth of the travel. To obtain accurate results for the entire explosion it is necessary to measure accurately both the very small rise in pressure during the early stages and the high and rapidly rising pressure near the end.

The diaphragm type of pressure indicator was selected for its inherent simplicity, adaptability, and high precision. Preliminary experiments indicated that any sort of passage between the explosion chamber and the diaphragm of the indicator, even a well-perforated backing plate, is undesirable where high precision is required and fast-burning mixtures of high energy content are used.

The indicator, as shown in figure 16, is therefore constructed so that the diaphragm forms part of the combustion chamber wall. An insulated electrode can be adjusted to make contact with the diaphragm when the pressure in the bomb has reached any desired value. When contact is

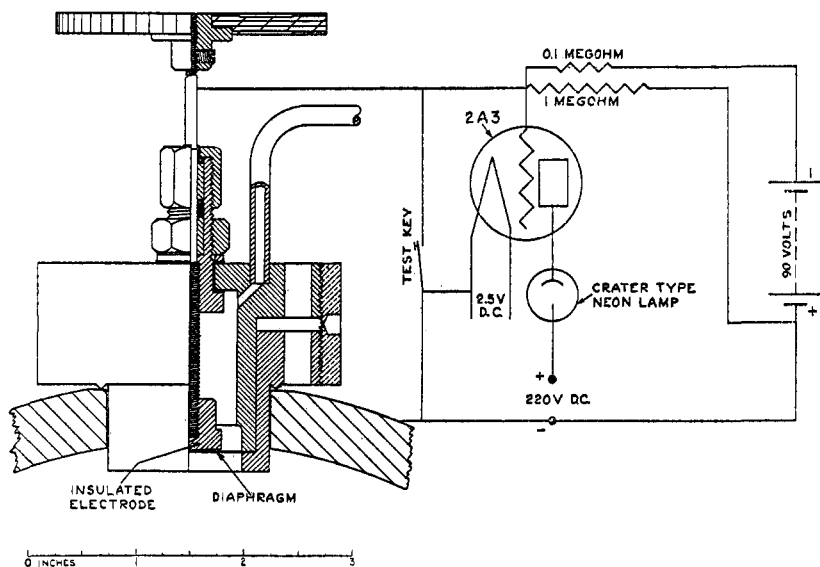

FIG. 16. Diaphragm pressure indicator, with recording circuit and lamp, designed for use with spherical bomb.

made, the negative bias on a vacuum tube (2A3) acting as a relay is reduced, permitting a larger current to flow through the plate circuit of the tube and a crater-type neon lamp. The lamp has a negligible time lag and may be readily photographed on the same film with the flame trace. A record is thus obtained of the instant that the predetermined pressure is attained in the bomb. Six similar indicators provide for recording six points on the time-pressure curve for each explosion, and several explosions from identical initial conditions will be required to establish the entire pressure curve.

In an indicator of the type shown in figure 16, the diaphragm need be

only strong enough to withstand the pressure to be measured, for it is supported by the electrode after contact is made. The space behind the diaphragm is normally open to the atmosphere, and the diaphragm makes contact after being deflected elastically by the pressure in the bomb. However, the space behind the diaphragm may be sealed if desired and a backing pressure applied to give the diaphragm an initial deflection into the bomb. If the electrode has been previously set to make contact when the diaphragm returns to its neutral position, the indicator will record the instant at which the pressure in the bomb is equal to the known constant backing pressure. In either case, the indicator may be calibrated in place, just before use, by setting the electrode, slowly increasing the pressure in the bomb until contact occurs, and measuring the pressure.

The only sources of significant error in an indicator of this type are variations in the static pressure required to cause contact on repeated trials and excessive inertia of the diaphragm, which would cause it to assume different positions under static and dynamic conditions. Preliminary tests with the six indicators mounted in the spherical bomb are being conducted to determine the diaphragm dimensions required for adequate strength and a satisfactory compromise between high reproducibility and low inertia error in different portions of the pressure range.

#### CONCLUSIONS

To be of greatest usefulness, a method for measuring flame speed must yield values of transformation velocity, which is the speed of flame in a direction normal to its surface and relative to the unburned charge. Of the various methods which have been used, those employing spherical flames are probably susceptible of the most rigorous analysis. Transformation velocities may be determined for explosions producing spherical flames either at constant pressure or at constant volume.

In both methods adequate control of the composition of the mixtures must be provided and all components must be gases or vapors. The light emitted by the explosions must be sufficiently actinic for photographic purposes. Flame speeds must not be so high that excessive pressure gradients are developed ahead of the flame front, or so low that convective rise is apparent during the explosion. Each method has, in addition, its individual advantages and limitations.

The constant-pressure or bubble method for measuring flame speeds has the great advantage that it requires the measurement neither of rapidly changing pressure nor of gas flow. All results are derived from a simple photographic record of flame spread which is rapidly obtained and easily analyzed. The value of the speed of flame in space as obtained by this method is a characteristic property of the explosive mixture dependent

only upon its transformation velocity and expansion ratio. Under favorable conditions all three of these properties can be evaluated by the bubble method, with a precision which is probably equal or superior to that attainable by any other method.

The principal disadvantage of the bubble method is that the partial pressure of water vapor in the explosive mixture is fixed by the temperature and composition of the soap film. It is therefore not practicable to maintain the temperature constant while the effect of variation in water vapor content is studied, or to maintain a constant ratio of moisture to active charge while temperature, pressure, and extent of dilution by inert gases are varied independently. This limitation is especially serious when the water is involved in the combustion reactions, as in mixtures of carbon monoxide and oxygen.

Materials of the soap film must not react with or dissolve any constituent of the explosive mixture and thus cause significant changes in its composition. In very rich mixtures the excess fuel burns in the surrounding atmosphere after the flame front has completely traversed the original mixture. In such cases values of transformation velocity and expansion ratio cannot be determined.

The spherical bomb of constant volume is adapted to the measurement of flame speeds over much wider ranges of charge composition, pressure, and temperature than is feasible with the bubble method. Charge composition may be varied at will, so long as all constituents are gases or vapors. The independent effects of pressure and temperature upon flame speeds may be isolated over a considerable range by making relatively small changes in initial pressure only, and the range may be greatly extended if provision is made for moderate variation of initial temperature. Conditions in the spherical bomb may thus be made to approach those prevailing in an engine, but greater opportunity exists for independent variation and control of conditions.

The gross mechanism of an explosion at constant volume is much more complex than for one at constant pressure, a more complicated apparatus and procedure are required for the determination of transformation velocity, and there is greater opportunity for error in the results. Perhaps the greatest single difficulty is in the accurate measurement of pressure. Indicators should be capable of recording faithfully both the very small initial rise in pressure during the early stages of the explosion and the high and rapidly rising pressures near the end. The necessity for evaluating slopes of the flame-travel and pressure-development curves involves errors which vary in magnitude with the position of the flame front. Greatest error in the results would be expected in the very early and very late stages.

It is hoped that future measurements of flame speed, through further development and use of both methods, will provide basic information which will clarify the mechanism of flame propagation and suggest practical means for further control of gaseous explosions. It is believed that such studies will yield results of many types, any or all of which may contribute to our knowledge of the combustion process and aid in its further improvement as a source of power in engines.

## REFERENCES

- (1) FIOCK, E. F., AND KING, H. K.: Natl. Advisory Comm. Aeronaut., Tech. Rept. No. 531 (1935).
- (2) FIOCK, E. F., AND ROEDER, C. H.: Natl. Advisory Comm. Aeronaut., Tech. Rept. No. 532 (1935).
- (3) FIOCK, E. F., AND ROEDER, C. H.: Natl. Advisory Comm. Aeronaut., Tech. Rept. No. 553 (1936).
- (4) LEWIS, B., AND VON ELBE, G.: J. Chem. Phys. **2**, 283 (1934).
- (5) MACHE, H.: Die Physik der Verbrennungserscheinungen. Veit and Co., Leipzig (1918).
- (6) SMITH, F. A.: Chem. Rev. **21**, 389 (1937).
- (7) STEVENS, F. W.: Natl. Advisory Comm. Aeronaut., Tech. Rept. No. 176 (1923).
- (8) STEVENS, F. W.: J. Am. Chem. Soc. **48**, 1896 (1926).
- (9) STEVENS, F. W.: Ind. Eng. Chem. **20**, 1018 (1928).
- (10) STEVENS, F. W.: J. Am. Chem. Soc. **50**, 3244 (1928).
- (11) STEVENS, F. W.: Natl. Advisory Comm. Aeronaut., Tech. Repts. Nos. 280, 305, 337, and 372, and Tech. Note No. 438.
- (12) STEVENS, F. W.: Sci. Monthly **32**, 556 (1928).